

VMP024

LARGE TELEVISION CEILING MOUNT

PRODUCT FEATURES

LARGE CEILING MOUNT

rotates 360° and has adjustable 0–15° tilt
mast extends 18"–30" from ceiling
opens from 17"–32" (left to right)
opens from 15.75"–26.25" (top to bottom)
holds most tv's/monitors 20"–29"
load capacity 165 lbs.
black finish

PRODUCT SPECIFICATIONS

FOR ARCHITECTS & ENGINEERS

The ceiling mount for the TV/monitor shall be a Video Mount Products (VMP) model VMP024. The monitor mount shall be constructed primarily of tubular steel and shall incorporate nylon filled nuts, and arc welds. The monitor mount shall be designed to allow adjustable tilt up to a maximum of 15° and must swivel 360°. The monitor mount shall have adjustable dimensions capable of holding a TV/monitor with screen sizes from 19" to 29". The mount shall adjust 17" to 32" (left to right) and open 15.75" to 26.25" (top to bottom). The mount must include a telescoping ceiling mast that adjusts from 18" to 30". The monitor mount shall have an integrated clamping mechanism that will secure the monitor on all sides. The load capacity shall be 165 lbs. The monitor mount shall be UL listed in the United States and Canada.

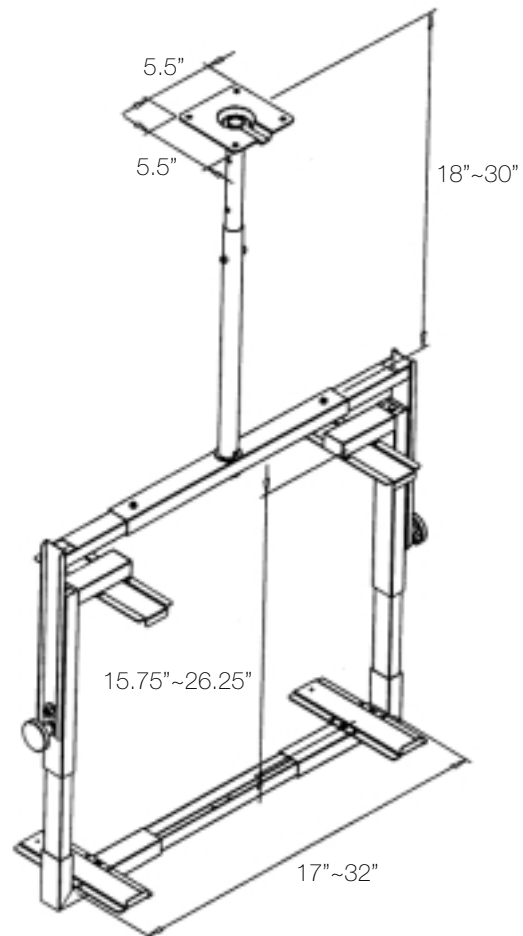

VMP Mounting Systems for
Video, Audio & Security
Video Mount Products



Video Mount Products
325 Log Canoe Circle
Stevensville, Maryland 21666
Phone 410.643.6390 Facsimile 410.643.6615
Website www.videomount.com

MOUNTING SYSTEMS FOR AUDIO, VIDEO & SECURITY